



Condensate Management

Pneumatech's condensate management portfolio includes solutions for separating, draining, detecting and treating oily condensate.

Water separators can be used downstream of the compressor instead of - or together with - the air receiver. We offer three types of condensate drains depending on your needs: a timer drain, a mechanical zero loss float drain and an electronic zero loss drain. Also for condensate treatment we give you the choice, i.e. between the cost-competitive ECOBOX solution and our premium, patented OWS technology.

WD - Water detector

Features & Benefits

- ▶ 24/7 peace-of-mind at a reasonable cost
 - Water level as low as 3 cl detected
 - Can be installed at every critical application in the compressed air network
- ▶ Transparency of operation
 - Alarm message on control panel
 - Potential-free contact to trigger alarm in control room
 - Test button for manual drainage
- ▶ Easy mechanical and electrical installation

General Specifications

- ▶ Water detector
- ▶ Operating pressure range:
0,2-16 barg/2,9-232 psig
- ▶ Operating temperature range:
1-60°C/34-140°F
- ▶ Power supply: 230VAC 50/60Hz



Options



Power supply
cable (2m)



Voltage-free contact
cable (5m)

Despite all efforts to make dryers, water separators and drains reliable, a failure can never be ruled out. The consequence of condensate water in your pipe network and operations can be dramatic: from corrosion and ice formation to bad product quality and process malfunctioning.

The installation of a Pressure Dew Point (PDP) sensor downstream brings a solution, but is often a too large investment.

Pneumatech's Water Detector (WD) provides peace-of-mind at an affordable cost. The WD gives an alarm as soon as a 3cl water level is detected. This alarm message is visible, audible and can be routed to a control room thanks to the potential-free contact. The ball valve at the outlet is meant to release water after an alarm situation and is closed during normal operation.

Technical Specifications for WD	
General characteristics	WD
First alarm level (cl)	3
Second alarm level (cl)	6,7
Max. power consumption (W)	10
Electrical connection	Solenoid plug type B - 2+PE
Potential free contact connection	M12 connector A-coding 4-pole Both Normally Open (NO) and Normally Closed (NC) possible
IP Protection	IP65
Physical characteristics	WD
Length (mm / inch)	160 / 6,3
Width (mm / inch)	69 / 2,71
Height (mm / inch)	116 / 4,5
Weight (kg / Lbs)	0,6 / 1,32
Connections	WD
Inlet	G1/2", horizontal + vertical
Outlet	Ball valve for condensate removal
Features	WD
Test button	Yes
Indicative LEDs	Yes
Potential free alarm	Yes

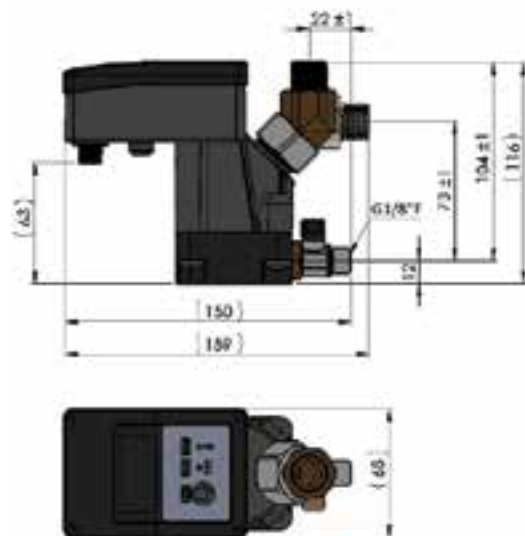

LD 100 - 204 - Zero loss drains

Features & Benefits

- ▶ No loss of compressed air
 - Automatic controlled drainage of condensate without any compressed air leak
- ▶ Maximum reliability
 - Integrated filter to prevent dirt from entering the valve diaphragm
 - Auto-repair algorithm: forced opening/closing cycles of the valve in case of malfunction
- ▶ Transparency of operation
 - Alarm message on control panel when drain is blocked
 - Potential-free contact to trigger alarm in control room
 - Test button for manual drainage
- ▶ Easy installation and maintenance
 - Straightforward mechanical and electrical connections
 - Wear kits available



General Specifications

- ▶ Zero-loss drain
- ▶ Operating pressure range:
0,2-16 barg/2,9-232 psig
- ▶ Operating temperature range:
1-60°C/34-140°F
- ▶ Compressor capacity:
from 180 up to 9500 m³/hr
- ▶ Power supply:
230VAC 50/60Hz
24VAC 50/60Hz
115VAC 50/60Hz

Options



Mounting kits



Wear kits



Power supply cable (2m)



Voltage-free contact cable (5m)



The series of LD zero-loss drains permit a controlled drainage of condensate without any compressed air leaks. All LD drains are equipped with an integrated storage tank, inside which a level sensor has been mounted. The sensor is controlled by an intelligent electronic circuit based on an 8-bit microprocessor logic. All drain functions are displayed on the control panel*. A test push button is available on the control panel for manual drainage. A built-in filter prevents the solenoid valve from clogging.

In case of trouble, the control circuit unlocks the drain pipes by carrying out a series of forced opening/closing cycles of the

solenoid valve. If this is not enough, the malfunction is reported outside by an alarm with potential-free contact to draw the attention of maintenance staff*.

The LD drains are produced in 10 different models with different flow rates. All versions are suitable for working with any type of condensate water.

*not applicable for the smallest model LD100

Technical specifications for LD 100 - 204

Pneumatech Variant → Specifications ↓	LD100	LD101	LD 101 Compact	LD 101 L	LD200	LD200 L	LD202	LD202 L	LD203	LD204
General characteristics										
Drain capacity (l/h)	1.6	4.03	3.3	5	8.07	10	16.14	20	85	200
Compressor capacity (m ³ /hr) ⁽¹⁾	180	450	378	450	900	900	1800	1800	9500	18000
Compressor capacity (cfm) ⁽¹⁾	106	265	222	265	530	530	1059	1059	5591	10594
Max. power consumption (W)	10									
Electrical connection	Solenoid plug type B – 2+PE									
Potential free contact connection	M12 connector A-coding 4-pole									
IP Protection	IP65	IP65	IP65	IP65	IP 65	IP 65	IP 65	IP 65	IP 65	IP 65
Physical characteristics										
Length (mm)	136	163	160	163	163	163	163	163	188	247
Length (inch)	5.4	6.4	6.3	6.4	6.4	6.4	6.4	6.4	7.4	9.7
Width (mm)	60	69	69	69	69	69	69	69	130	130
Width (inch)	2.4	2.7	2.7	2.7	2.7	2.7	2.7	2.7	5.1	5.1
Height (mm)	120	140	120	140	155	155	214	214	230	230
Height (inch)	4.7	5.5	4.7	5.5	6.1	6.1	8.4	8.4	9.1	9.1
Weight (kg)	0.42	0.6	0.5	0.6	0.7	0.7	1.2	1.2	2.8	3.45
Weight (lbs)	0.9	1.3	1.1	1.3	1.5	1.5	2.6	2.6	6.2	7.6
Connections										
Inlet	G1/2"	G1/2"	G1/2" (F)	G1/2" (F)	G1/2" (F)	2 x G1/2" (F)	G1/2" (F)	2 x G1/2" (F)	2 x G1/2" (F)	2 x G1/2" (F) + 1 x G3/4" (F)
Outlet	1 x Ø12	1 x Ø12	1 x Ø12	1 x Ø12	1 x Ø12	1 x Ø12	1 x Ø12	1 x Ø12	1 x Ø12	1 x Ø12
Features										
Test button	Yes									
Indicative LEDs	No	Yes								
Potential free alarm	No	Yes (NC/NO)								

1. The calculation of compressor capacity is based on the maximum condensate drainage of a compressor aftercooler in moderate climate conditions.

TD - Timer drain

Features & Benefits

- ▶ Guaranteed reliability
 - Robust solenoid, made in Europe
 - Integrated Y-filter to prevent dirt from entering the valve
 - Large cross-section openings
- ▶ Endless flexibility
 - No limitations in air flow
 - Cycle and valve opening intervals can be set independently of each other
- ▶ IP65 enclosed
- ▶ Transparency of operation
 - Test button and operation indicator

Pneumatech's TD condensate drains discharge the condensate automatically, based on pre-set time intervals. The opening and closing times can be set with high flexibility, which make the drains suitable for almost all capacities. TD drains are selected in heavy-duty operations, where the large cross-sections opening and the simplicity of the drain are highly valued.

High-pressure TD drains are available on request.



Technical specifications	
Pressure range	0-16 barg/ 0-232 psig
Supply voltage	24VAC 50/60Hz & 230VAC 50/60Hz (CE)
Electrical connection	DIN43650A
Inlet/outlet connections	G 1/2" (CE) NPT 1/2" (UL)
Environmental protection	IP65
Max. compressor capacity	No limit
Min/Max operating temperature	1-50°C/ 34-122°F
Timer cycle	On: 0,5 – 10 s; Off: 0,5 – 45 min. including test feature
Valve type	2/2 direct acting
Valve orifice	4.5 mm- 0,177"
Valve seal	FKM

MD - Mechanical zero-loss float drain

Pneumatech's MD drain discharges the condensate automatically and without compressed air losses up to 16 barg. A floating body rises and falls with the condensate level in a collecting chamber; and opens/closes a mechanical drain valve. The condensate collecting chamber is closed off from the compressed air flow when the drain is depressurized.

The drain is equipped with an integrated venting function, which prevents the risks of possible air slots. The MD has a well-proven, rugged metal design with threaded connections at inlet and outlet.



Features & Benefits

- ▶ No loss of compressed air
 - Automatic controlled drainage of condensate without any compressed air leak
- ▶ Plug-and-play solution
 - No power supply needed
 - No programming or calibration
- ▶ Guaranteed reliability
 - Large cross-section openings
 - Well-proven, rugged aluminum design
 - Integrated venting function to prevent air slots
- ▶ Transparency of operation
 - Manual drain valve for system discharge and operational check

Technical specifications

Pressure range	0-16 barg / 0-232 psig
Inlet/outlet connections	G ½" (CE)
Max. water discharge capacity	250 l/h @ 7 barg / 0,147 cfm @ 101 psig 360 l/h @ 16 barg / 0,212 cfm @ 232 psig
Max compressor capacity (without dryer)	5.400 m³/hr / 3178 cfm
Length	156 mm / 6,14"
Width	108 mm / 4,25"
Height	111 mm / 4,37"
Weight	0,9 kg / 2 lbs

ECOBIX 2 - 4 - Oil water separators

Features & Benefits

- ▶ Excellent performance
 - 2-stage filtration with advanced adsorption media
 - After separation, water contains oil levels below 15 ppm⁽¹⁾
 - Emulsion treatment possible (on request)
- ▶ Eliminating potential health issues
 - No standing or stagnant water
- ▶ Plug-and-play installation and service
 - Connection points at inlet
 - Compact footprint
 - No pre-soaking required
- ▶ Time-based service indicator and sampling kit (standard) to verify outlet concentration on a regular base.



Options



Extra 4 port kit



Pneumatech extends its cost-competitive ECOBOX condensate cleaning solution with 3 more models, up to 1400 m³/hr. The models are designed according to the same success factors: reliable double adsorption with recycled glass media, compact footprint, and easy installation and service.

Additionally the ECOBOX 2 - 4 has 4 connections points at the inlet; and a sample test point at the outlet.

Technical specifications for ECOBOX 2-4				
		ECOBOX 2	ECOBOX 3	ECOBOX 4
Maximum rated flow - normal climate ⁽²⁾	l/s	53	158	389
	m ³ /hr	190	570	1400
	cfm	112	335	824
Connections	Inlet	4 x 12mm	4 x 12mm	4 x 12mm
		4 x 1/2"	4 x 1/2"	4 x 1/2"
	Outlet	12mm	20mm	20mm
		1/2"	3/4"	3/4"
Weight	kg	2,7	3,6	14,8
	lbs	6,0	7,9	32,6
Dimensions	Length (mm)	215	345	432
	Length (inch)	8,46	13,58	17,01
	Width (mm)	257	282	495
	Width (inch)	10,12	11,10	19,49
	Height (mm)	500	654	989
	Height (inch)	19,69	25,75	38,94
Service life for filter ⁽³⁾		4,000 Operating Hrs	4,000 Operating Hrs	4,000 Operating Hrs

- 15ppm is generally well below the acceptance level for disposal in the sewage, but due to strongly varying international and local regulations, it is the user's responsibility to consult local waste water discharge regulations and ensure compliance.
- In tropical climates (high ambient temperatures and humidity levels), the air generally contains more water vapor. The extra condensate, generated during the compression and cooling process of the air, shortens the contact time in the device, leaving less time for the media to absorb the oil. Climatic conditions used in the table above are defines as follows:
 - Cold climate conditions: average ambient temperature of 20°C/ 68°F- relative humidity of 50 %
 - Normal climate conditions: average ambient temperature of 25°C/ 75°F - relative humidity of 50%
 - Hot climate conditions: average ambient temperature of 35°/ 95°F - relative humidity of 70 %
- Pneumatech assumes as well maintained compressor plant and reasonable operating conditions. Performance on mineral or mineral-based lubricants should be as above, irrespective of compressor type, condensate drain technology or climate, provided the condensate produced is not a stable emulsion.

OWS 25 - 5300 - Oil water separators

Features & Benefits

- ▶ Stable and reliable performance for weak as well as stable emulsions thanks to patented dual stage filtration technology
 - Filtering all types of condensate
 - No risk of spillage thanks to large capacity chamber design
- ▶ Eliminating all potential health issues
 - No standing or stagnant water
 - Optional anti-bacteria kit
- ▶ Accurate and quick indication of filter replacement thanks to saturation indicator
- ▶ Overflow indicator signalizes if the emulsion is flowing too quickly through the media
- ▶ DIBT certified
- ▶ Hassle-free maintenance with genuine service kits
- ▶ Optimized serviceability
 - Easy to remove first stage filtration bags
 - 2nd stage filter cartridge adapted from outside for easy exchange
 - Built-in wheels for larger cartridge for easy transport

General Specifications

- ▶ Service interval 4000 hours
- ▶ Oil water separator
- ▶ Clean wastewater with oil content at the outlet at just 10ppm, and the possibility of going to as low as 5ppm depending on the set-up
- ▶ Flow range at mild ambient conditions: 43-8998 m³/hr/25-5296 cfm
- ▶ Standard version with activated carbon for unstable emulsions such as those containing mineral oil
- ▶ Organoclay version for stable emulsions with synthetic oil as well as for polypropylen based lubricants



Options

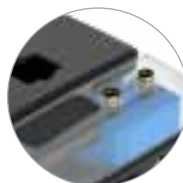

Multiple inlet manifold

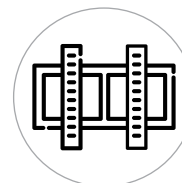

Wall mount brackets

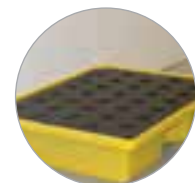

Spill container



Photoelectric sensor



Pneumatech offers with the new OWS generation a patented way to turn oily condensate from mineral oil, synthetic oil as well as polypropylene based lubricants into harmless water that can be drained away, while capturing the oil to be easily disposed of in an environmentally friendly manner. The multi-stage separation process, using both buoyant oleophilic filters and activated carbon/organoclay ensures exceptional performance, lower disposal costs and trouble free operation.

The OWS range eliminates oil through multi-stage filtration rather than the conventional gravity systems which have limitations on the type of condensate that can be treated. As a result, the OWS separator capacity is not linked to the type of emulsion collected since. The OWS range also eliminates stable emulsions by using organoclay cartridge in the second filtration stage.

Technical specifications for OWS 75 – OWS 5000

Installation Type	Pneumatech Variant → Specifications ↓	Units	OWS 25	OWS 53	OWS 106	OWS 180	OWS 360	OWS 636	OWS 1325	OWS 2650	OWS 5300
Complete installation ⁽¹⁾ with Dryer ⁽²⁾	Cold Climate ³	m ³ /hr ⁽⁶⁾	58	119	241	407	817	1440	2999	5998	11995
		cfm ⁽⁶⁾	34	71	141	240	480	848	1766	3532	7065
	Mild Climate ⁴	m ³ /hr ⁽⁶⁾	43	90	180	306	612	1080	2250	4500	9000
		cfm ⁶	25	53	106	180	360	636	1325	2650	5300
	Hot Climate ⁵	m ³ /hr ⁽⁶⁾	22	43	86	148	299	526	1094	2189	4378
		cfm ⁽⁶⁾	13	26	52	88	175	309	645	1289	2578
Complete installation ⁽¹⁾ without Dryer ⁽²⁾	Cold Climate ³	m ³ /hr ⁽⁶⁾	72	151	299	511	1019	1800	3751	7499	15001
		cfm ⁽⁶⁾	42	88	133	300	601	1060	2208	4417	8833
	Mild Climate ⁴	m ³ /hr ⁽⁶⁾	54	112	227	382	767	1350	2812	5627	11250
		cfm ⁽⁶⁾	32	66	133	225	451	795	1656	3313	6625
	Hot Climate ⁵	m ³ /hr ⁽⁶⁾	32	61	122	205	410	724	1512	3020	6041
		cfm ⁽⁶⁾	18	36	71	121	242	427	890	1779	3558
Connections	inlet (BSP/NPT)		1x1/2"	2x1/2"	2x1/2"	2x3/4"	2x1/2"	2x3/4"	2x3/4"	2x3/4"	-
	outlet (BSP/NPT)		1x1/2"	1x1/2"	1x1/2"	1x3/4"	1x1/2"	1x3/4"	1x3/4"	1x1"	-
Dimensions	Length	mm	470	680	680	750	750	945	945	945	-
		inch	18,5	27	27	30	30	37	37	37	-
	Width	mm	165	255	255	546	546	650	695	1185	-
		inch	6,5	10	10	21,5	21,5	26	27	47	-
	Height	mm	610	762	762	889	1041	1092	1092	1092	-
		inch	24	30	30	35	41	43	43	43	-
	Weight	kgs	4	13	15	25	26	28	30	60	-
		lbs	9	29	33	55	57	62	66	132	-

Reference conditions

Relative air humidity: 60%

Air inlet temperature: 25°C (77°F) Running hours per day: 12 hrs

Effective working pressure: 7 bar (102 psi)

Note: Capacity is based on the compressor running at 7 barg / 100 psig for 12 hours per day, with all condensate from the compressor, the air receiver, the filters and fridge dryer being piped into the unit.

Correction factors

Relative humidity	%	0.5	0.6	0.7	0.8	0.9	-
	Correction factor	1.10	1.00	0.85	0.74	0.66	-
Ambient temperature	°C	15	20	25	30	35	40
	Correction factor	1.33	1.17	1.00	0.76	0.50	0.30
Running hours per day	hrs	12	18	24	-	-	-
	Correction factor	1	0.88	0.75	-	-	-

CA - Air cooled aftercoolers

Features & Benefits

- ▶ Highly efficient axial fans
- ▶ Cooling down to 10°C/18°F above ambient
- ▶ Negligible pressure drop
- ▶ Robust construction and compact design
- ▶ Easy to dismantle for cleaning

General Specifications

- ▶ Air cooled aftercooler
- ▶ Max. operating pressure: 15 barg/218 psig
- ▶ Operating temperature: 170°C/338°F
- ▶ Approach above ambient temperature: 10°C/18°F
- ▶ Flow Rate: 66 to 4500 Nm³/hr (39 to 2649 cfm)



Compressed air will always be 100% saturated with water when it leaves a compressor. But also the outlet temperature has an important influence on the water load downstream the compressor. In order to minimize the load – and thus size – of the downstream refrigeration or adsorption dryer, it is therefore recommended to install a highly efficient aftercooler between the compressor and the dryer.

Pneumatech's air cooled aftercoolers CA 1-14 consist of a reliable axial fan with supreme efficiency. The fan forces ambient air over the copper tubes and aluminum fins of the heat exchanger. Hence the compressed air is cooled down to only 10°C/18°F above ambient temperature.

In this way, the CA is a simple product, but with a major impact on the investment and lifecycle cost of your downstream equipment!

Technical specifications for air cooled aftercoolers CA 1-14

Pneumatech Variant → Specifications ↓	Units	CA 1	CA 2	CA 3	CA 4	CA 5	CA 6	CA 7	CA 8	CA 9	CA 10	CA 11	CA 12	CA 13	CA 14
Flow ⁽¹⁾	m ³ /hr	66	126	222	294	390	522	774	990	1260	1560	1890	2520	3090	4500
	scfm	39	74	131	173	230	307	456	583	742	918	1112	1483	1819	2649
PipeSize	inch	G1"	G1"	G1 1/2"	G1 1/2"	G2"	G2"	G2"	G2 1/2"	DN100	DN100	DN100	DN100	DN125	DN125
Power Supply	Ph/Volt/Fr	1/230/50	1/230/50	3/400/50	3/400/50	3/400/50	3/400/50	3/400/50	3/400/50	3/400/50	3/400/50	3/400/50	3/400/50	3/400/50	3/400/50
Fan	Ø mm -W	Ø250-45W	Ø250-45W	Ø350-110W	Ø400-130W	Ø500-540W	Ø500-540W	Ø630-370W	Ø630-370W	Ø800-1470W	Ø800-1470W	Ø800-1470W	Ø800-1470W	2xØ800-1470W	2xØ800-1470W
Dimensions	A (mm)	957	957	1024	1024	1136	1136	1450	1450	1634	1634	1800	2000	2090	2300
	A (inch)	37.7	37.7	40.3	40.3	44.7	44.7	57.1	57.1	64.3	64.3	70.9	78.7	82.3	90.6
	B (mm)	320	320	368	368	355	355	465.5	465.5	564.1	564.1	790	795	830	850
	B (inch)	12.6	12.6	14.5	14.5	14.0	14.0	18.3	18.3	22.2	22.2	31.1	31.3	32.7	33.5
	C (mm)	400	400	490	490	764	764	775	775	1616	1616	1560	1740	1850	2010
	C (inch)	15.7	15.7	19.3	19.3	30.1	30.1	30.5	30.5	63.6	63.6	61.4	68.5	72.8	79.1
Weight	kg	19	20	27	29	44	48	61	66	127	143	148	166	212	315
	lbs	41.9	44.1	59.5	63.9	97.0	105.8	134.5	145.5	280.0	315.3	326.3	366.0	467.4	694.5

1. Flow refers to 1 barg and 20°C at 7 barg operating pressure.

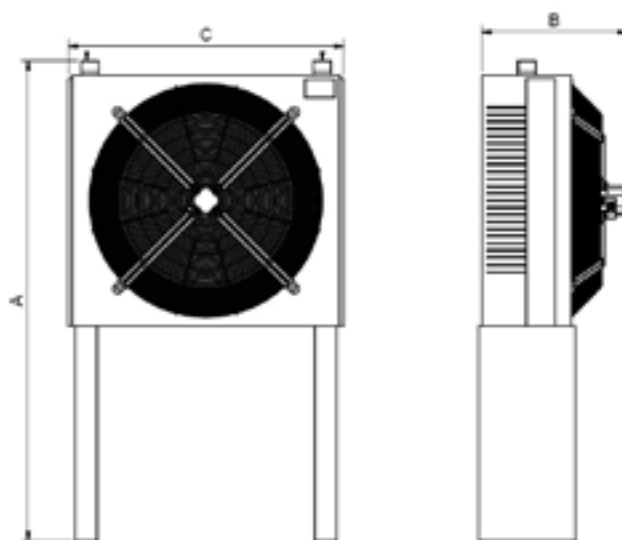

Note : In- and outlet connections can be chosen freely in the 4 corners of the heat exchanger

CW 1 - 17 - Water cooled aftercoolers

Features & Benefits

- ▶ Close temperature approach thanks to counter-current heat exchange
- ▶ Robust shell-and-tube design: stainless steel tubes within coated shell
- ▶ Negligible pressure drop
- ▶ Compact design
- ▶ Detailed calculations available on request

General Specifications

- ▶ Water cooled aftercooler
- ▶ Operating pressure of compressed air: 0-16 barg/0-232 psig
- ▶ Operating temperature of compressed air: 2-200°C/35-392°F
- ▶ Flow Rate: 132 to 45570 Nm³/hr/
78 to 26821 cfm

